



FLOWCON FABRIC DIFFUSERS

Installation, Operation and Maintenance Manual

Project Title: _____

Location Name: _____

Date: _____

Service Contractor: _____

Telephone Number: _____

CONTENTS

1.0 INTRODUCTION

1.1 Warranty

2.0 INSTALLATION

2.1 Inventory

2.2 Suspension

A. Double

2.3 Installation of fabric Diffuser

2.4 Start Up

2.5 Operation

3.0 MAINTENANCE

3.1 Cleaning

3.2 Repair

4.0 DRAWINGS & REFERENCE

1.0 INTRODUCTION

The following manual for Flowcon air diffuser outlines installation, operation and service requirements. It is good practice to know as much as possible about your fabric air diffuser system before trying to install or operate it. Due to the custom nature of fabric air diffusers not all possibilities are addressed in this manual. In cases where a special application is not covered, the customer or installer can obtain information from A.D.C. Inc. sales representative or from A.D.C. Inc. directly.

1.1 Warranty

FlowCon diffusers now include a 10 year non prorated warranty program for our Premium polyester and fiberglass systems and 5 year non prorated warranty program for our polyethylene, vinyl and X- static systems. The FlowCon warranty is for replacement credit, based on the original amount of system cost excluding suspension system. The warranty is not available in the form of a cash payment. The warranty covers materials, fabrication, and workmanship of the fabric portion of the system only. Warranty coverage begins at the time of shipment. This warranty also requires that the original system be designed within requirement design guidelines – including inlet velocity of maximum of 1500 FPM and two row suspension systems for 30" diameter and larger and 3 row suspension system for diameters larger than 52" must be installed. For warranty to be valid all installation and maintenance instructions must be followed, in addition to regular maintenance of the supply air units and filters. Fabric diffuser maintenance schedule must be submitted at time of warranty claim. Warranty excludes damage to fabric from improper installation, poor maintenance, abuse, abrasion, caustic chemicals, exposure to high temperature (over 180 degrees F), failure to specify all system requirements, or any unauthorized modification to system. Warranty does not cover any labor, equipment rental, or freight charges incurred as a result of executing warranty. Contact Sales with warranty questions.

2.0 INSTALLATION

2.1 Inventory

Before installing fabric diffuser system read all general information in the following sections. For best results use this manual in conjunction with the mechanical blue print or diffuser layout if supplied. Check the shipment carefully. Diffuser systems are shipped in polyethylene bags or boxes. Larger orders will be shipped in large skidded containers with individual contents in polyethylene bags or folded. All packages will be labeled with diffuser diameter and length. Make sure contents match the packing list. Note any missing or damaged pieces and notify your supplier before starting installation. Check length & diameters before installing & contact supplier before installation. (Not responsible for labor costs accrued from installing incorrect lengths or layouts.)

2.2 Suspension

A DOUBLE CABLE SUSPENSION

When installing a two cable suspension system, it is important to review the diffuser layout. It is important to notice location of elbows, tees, or reductions. Improper placement of the cable may cause wear on the fabric.

Cable and turnbuckle installation are similar to single cable suspension systems. There are different variations of double cable systems. Refer to the diagrams below. Snap hooks can be extended so that all cables will be at the same elevation. Fittings may have quick connect joints such as zippers to ease the installation and maintenance of the system. NOTE: 6:00 & 12:00 suspension is similar to 12:00 suspension with cable to cable distance the same as 3 & 9:00 suspension. For Triple suspension use a combination of either 2:00, 10:00 with 12:00 or 3:00, 9:00 with 12:00

3:00 & 9:00

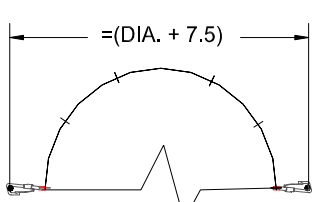

3:00 & 9:00 EXTENDED

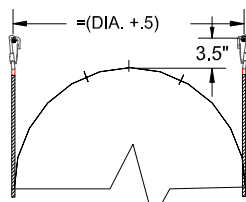

2:00 & 10:00

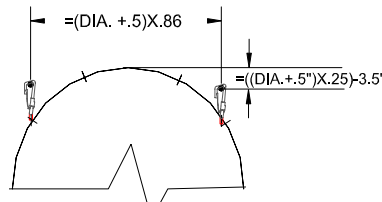

2:00 & 10:00 EXTENDED

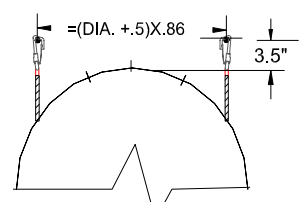

2.3 INSTALLATION OF FABRIC DIFFUSER

When handling a diffuser prior and during installation, please keep anything that comes in contact with the diffuser clean. If a diffuser is to be laid out on the floor, make sure floor is clean or something is laid down to protect diffuser from dirt or debris on the ground that could catch on air jets and damage diffuser during installation.

- 1.) Slide the snaphooks down the cable.
- 2.) Pull diffuser down the cable until fully extended.
- 3.) Pull open end of diffuser and slip over metal collar or metal duct (about 6-12").
- 4.) Install worm gear band around diffuser to secure it to metal duct.

Note: Worm gear bands are perforated and self taping screws can be used to help secure band and keep from slipping. (Screws not included).

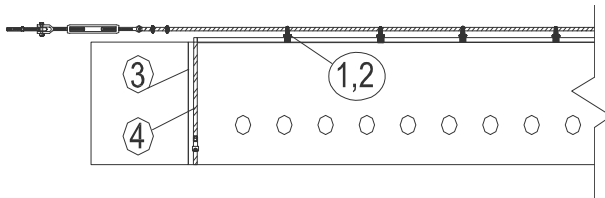

2.4 START UP

Turn on air handler and inflate diffuser. With the diffuser inflated, anchor the end cap or last snap hook of the diffuser to the support cable as shown. This will keep the diffuser fully extended when diffuser is deflated and keep the diffuser from sliding.

NOTE: If the diffuser system flutters after installation, check to see if air handler is operating at its designed air volume and static pressure. Fluttering can cause damage to fabric shortening life of system.

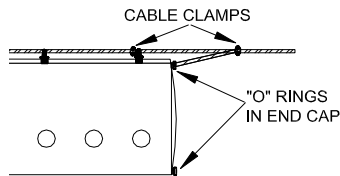

2.5 Operation

Flowcon air diffusers systems are engineered to be self balancing and no adjustments need to be made after initial start up. If there are areas which discharge air velocity is to high air jet plugs can be installed to stop or reduce the amount of air. (Consult factory for sizing)

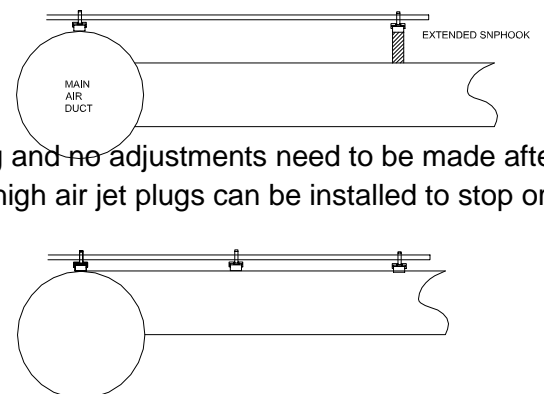

3.0 MAINTENANCE

3.1 CLEANING

Washing and cleaning of Flow / Con fabric air diffusers should be carried out in accordance with the following instructions.

- 1.) Hand or power wash with clean water @ max. 140` F. Diffusers made of polyester may be machined washed (if diffusers are in small enough sections and gentle cycle).
- 2.) If the diffusers are heavily soiled, use mild laundry detergent in accordance with manufacturer's instructions. (repeat if necessary)
- 3.) After washing, rinse with clean cold water.
- 4.) Do not dry in dryer, hang dry.

Because Flow Con diffusers are laundered so infrequently, extremely soiled diffusers will require laundering more than once. In our experience we suggest contacting a local industrial laundering service equipped with industrial laundering equipment to clean the diffusers properly.

3.2 REPAIR

Consult your sales representative first in order to determine if the diffuser can be repaired on site or if it has to be sent back to the factory. Patch kits are available.

TYPE A) Polyethylene and Polyester

- 1.) Clean the surface of the Flow Con fabric air diffuser that needs repair in accordance with the above instructions.
- 2.) For tears longer than eight inches cut a patch 1 to 2 inches longer and wider than patch.
- 3.) Apply the repair tape to fabric and smooth out any air bubbles by smoothing to the edge of patch.
- 4.) Wait 5 minutes before turning unit back on.

TYPE B) Vinyl (similar to above)

- 1.) Clean the surface of the Flow Con fabric air diffuser that needs repair in accordance with the above instructions. Clean surface with a solvent to remove possible oil residue.
- 2.) For tears longer than eight inches cut a patch 1 to 2 inches longer and wider than patch.
- 3.) Apply the repair tape to fabric and smooth out any air bubbles by smoothing to the edge of patch.
- 4.) Wait 5 minutes before turning unit back on.

4.0 DRAWINGS AND REFERENCE (SEE ATTACHED FOR DRAWINGS)